

# Chapter 2: Operating-System Structures

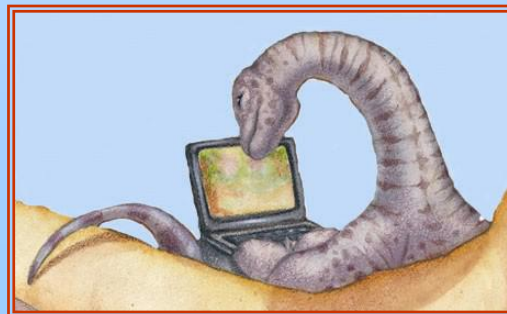



# Chapter 2: Operating-System Structures

- Operating System Services
- User Operating System Interface
- System Calls
- Types of System Calls
- System Programs
- Operating System Design and Implementation
- Operating System Structure
- Virtual Machines
- Operating System Generation
- System Boot





# Objectives

- To describe the services an operating system provides to users, processes, and other systems
- To discuss the various ways of structuring an operating system
- To explain how operating systems are installed and customized and how they boot





# Operating System Services

- One set of operating-system services provides functions that are helpful to the user:
  - User interface - Almost all operating systems have a user interface (UI)
    - ▶ Varies between Command-Line (CLI), Graphics User Interface (GUI), Batch
  - Program execution - The system must be able to load a program into memory and to run that program, end execution, either normally or abnormally (indicating error)
  - I/O operations - A running program may require I/O, which may involve a file or an I/O device.
  - File-system manipulation - The file system is of particular interest. Obviously, programs need to read and write files and directories, create and delete them, search them, list file information, permission management.





# Operating System Services (Cont.)

- One set of operating-system services provides functions that are helpful to the user (Cont):
  - Communications – Processes may exchange information, on the same computer or between computers over a network
    - ▶ Communications may be via shared memory or through message passing (packets moved by the OS)
  - Error detection – OS needs to be constantly aware of possible errors
    - ▶ May occur in the CPU and memory hardware, in I/O devices, in user program
    - ▶ For each type of error, OS should take the appropriate action to ensure correct and consistent computing
    - ▶ Debugging facilities can greatly enhance the user's and programmer's abilities to efficiently use the system





# Operating System Services (Cont.)

- Another set of OS functions exists for ensuring the efficient operation of the system itself via resource sharing
  - **Resource allocation** - When multiple users or multiple jobs running concurrently, resources must be allocated to each of them
    - ▶ Many types of resources - Some (such as CPU cycles, main memory, and file storage) may have special allocation code, others (such as I/O devices) may have general request and release code.
  - **Accounting** - To keep track of which users use how much and what kinds of computer resources
  - **Protection and security** - The owners of information stored in a multiuser or networked computer system may want to control use of that information, concurrent processes should not interfere with each other
    - ▶ **Protection** involves ensuring that all access to system resources is controlled
    - ▶ **Security** of the system from outsiders requires user authentication, extends to defending external I/O devices from invalid access attempts
    - ▶ If a system is to be protected and secure, precautions must be instituted throughout it. A chain is only as strong as its weakest link.





# User Operating System Interface - CLI

CLI allows direct command entry

- ▶ Sometimes implemented in kernel, sometimes by systems program
- ▶ Sometimes multiple flavors implemented – **shells**
- ▶ Primarily fetches a command from user and executes it
  - Sometimes commands built-in, sometimes just names of programs
    - » If the latter, adding new features doesn't require shell modification





# User Operating System Interface - GUI

- User-friendly **desktop** metaphor interface
  - Usually mouse, keyboard, and monitor
  - **Icons** represent files, programs, actions, etc
  - Various mouse buttons over objects in the interface cause various actions (provide information, options, execute function, open directory (known as a **folder**))
  - Invented at Xerox PARC
- Many systems now include both CLI and GUI interfaces
  - Microsoft Windows is GUI with CLI “command” shell
  - Apple Mac OS X as “Aqua” GUI interface with UNIX kernel underneath and shells available
  - Solaris is CLI with optional GUI interfaces (Java Desktop, KDE)







# System Calls

- Programming interface to the services provided by the OS
- Typically written in a high-level language (C or C++)
- Mostly accessed by programs via a high-level **Application Program Interface (API)** rather than direct system call use
- Three most common APIs are Win32 API for Windows, POSIX API for POSIX-based systems (including virtually all versions of UNIX, Linux, and Mac OS X), and Java API for the Java virtual machine (JVM)
- Why use APIs rather than system calls?

(Note that the system-call names used throughout this text are generic)





# Example of System Calls

- System call sequence to copy the contents of one file to another file

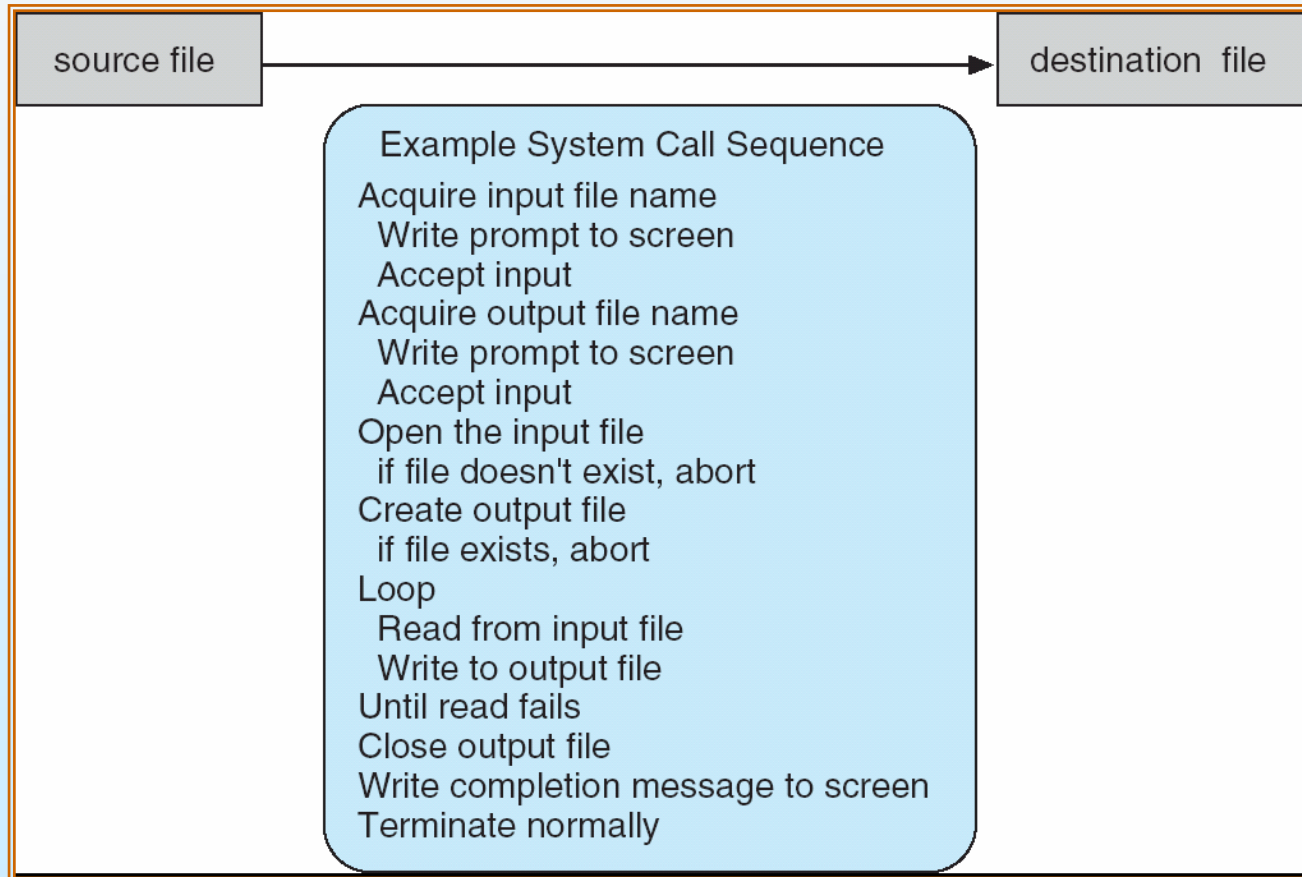



# Example of Standard API

- Consider the ReadFile() function in the
- Win32 API—a function for reading from a file

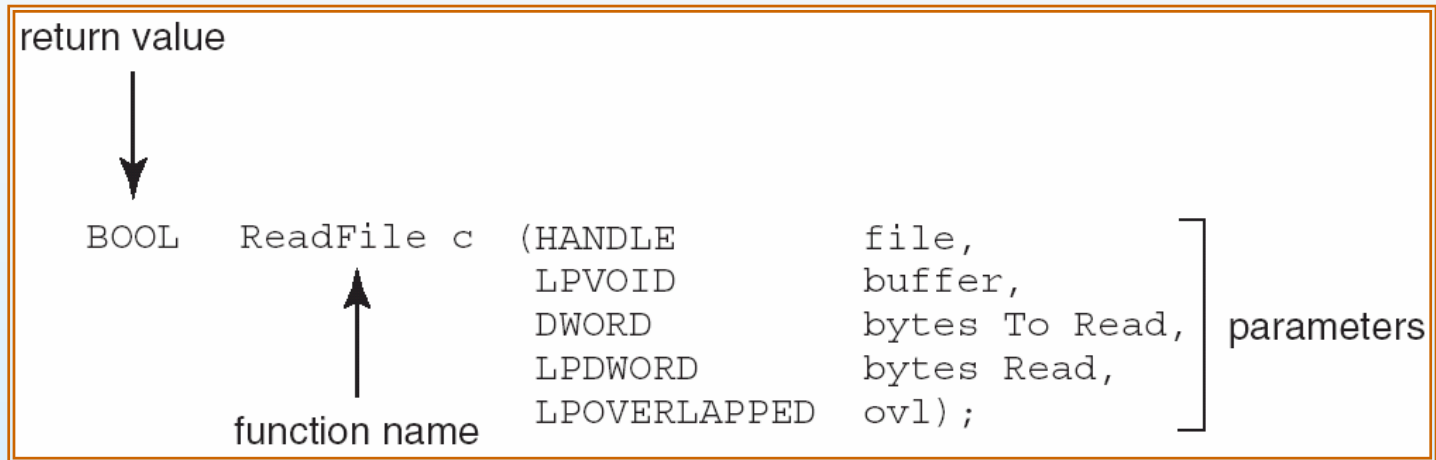

- A description of the parameters passed to ReadFile()
  - HANDLE file—the file to be read
  - LPVOID buffer—a buffer where the data will be read into and written from
  - DWORD bytesToRead—the number of bytes to be read into the buffer
  - LPDWORD bytesRead—the number of bytes read during the last read
  - LPOVERLAPPED ovl—indicates if overlapped I/O is being used





# System Call Implementation

- Typically, a number associated with each system call
  - System-call interface maintains a table indexed according to these numbers
- The system call interface invokes intended system call in OS kernel and returns status of the system call and any return values
- The caller need know nothing about how the system call is implemented
  - Just needs to obey API and understand what OS will do as a result call
  - Most details of OS interface hidden from programmer by API
    - ▶ Managed by run-time support library (set of functions built into libraries included with compiler)



# API – System Call – OS Relationship

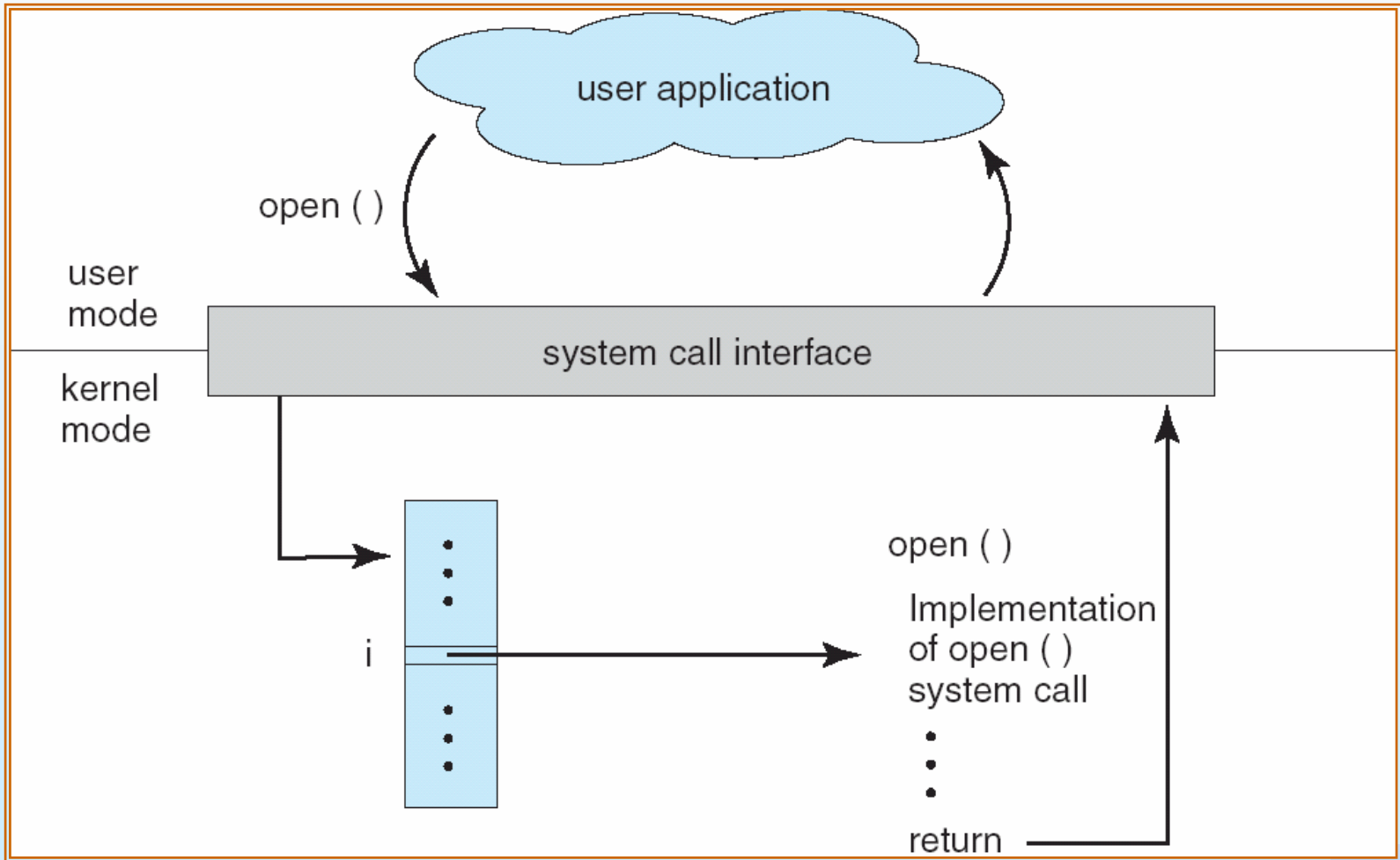



# Standard C Library Example

- C program invoking printf() library call, which calls write() system call

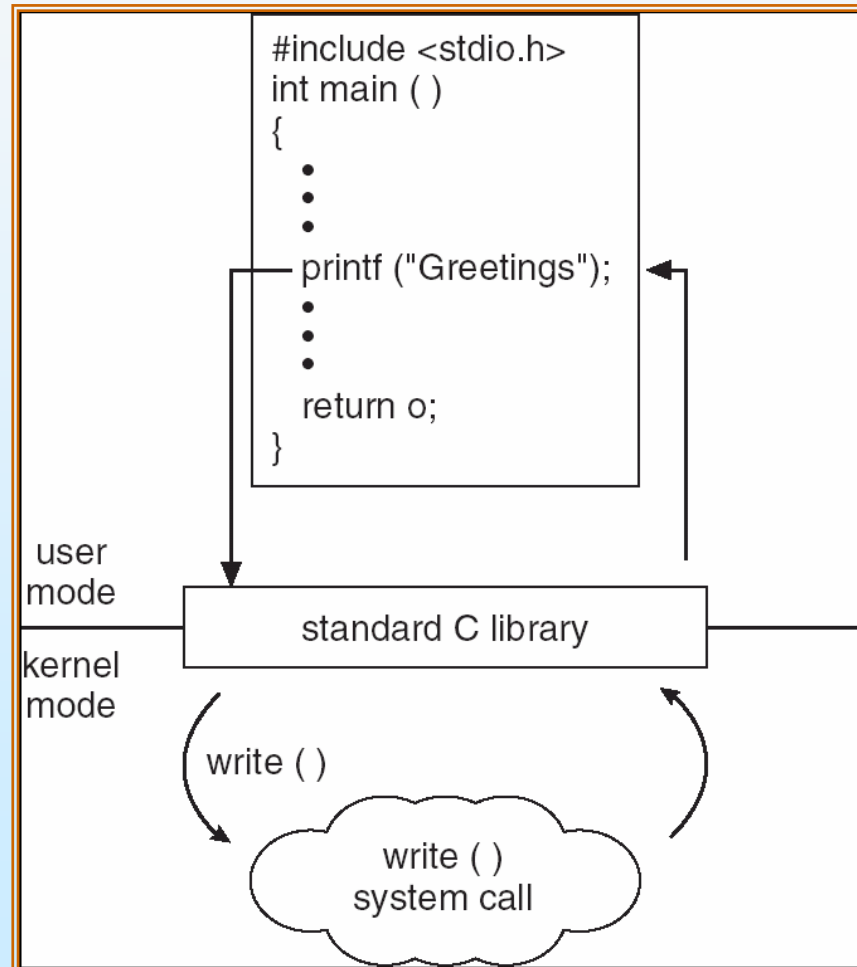



# System Call Parameter Passing

- Often, more information is required than simply identity of desired system call
  - Exact type and amount of information vary according to OS and call
- Three general methods used to pass parameters to the OS
  - Simplest: pass the parameters in *registers*
    - ▶ In some cases, may be more parameters than registers
  - Parameters stored in a *block*, or table, in memory, and address of block passed as a parameter in a register
    - ▶ This approach taken by Linux and Solaris
  - Parameters placed, or *pushed*, onto the *stack* by the program and *popped* off the stack by the operating system
  - Block and stack methods do not limit the number or length of parameters being passed





# Parameter Passing via Table

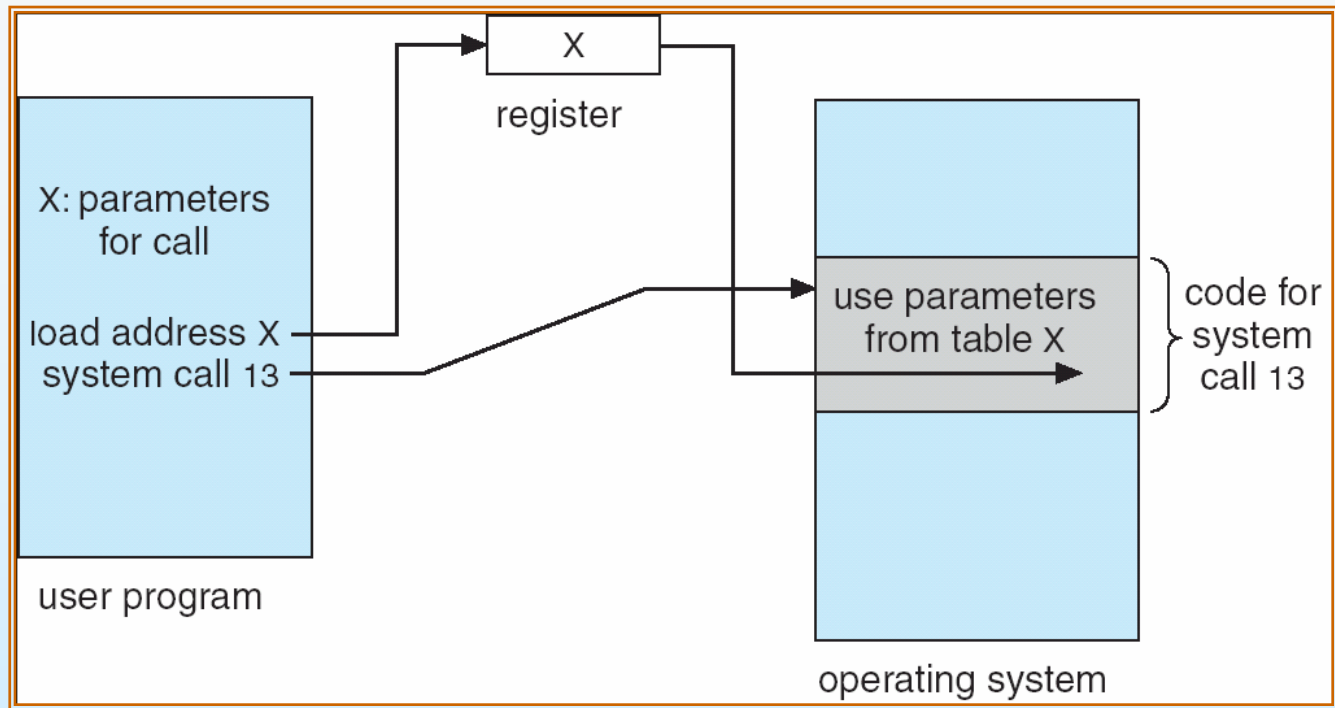





# Types of System Calls

- Process control
- File management
- Device management
- Information maintenance
- Communications





# MS-DOS execution

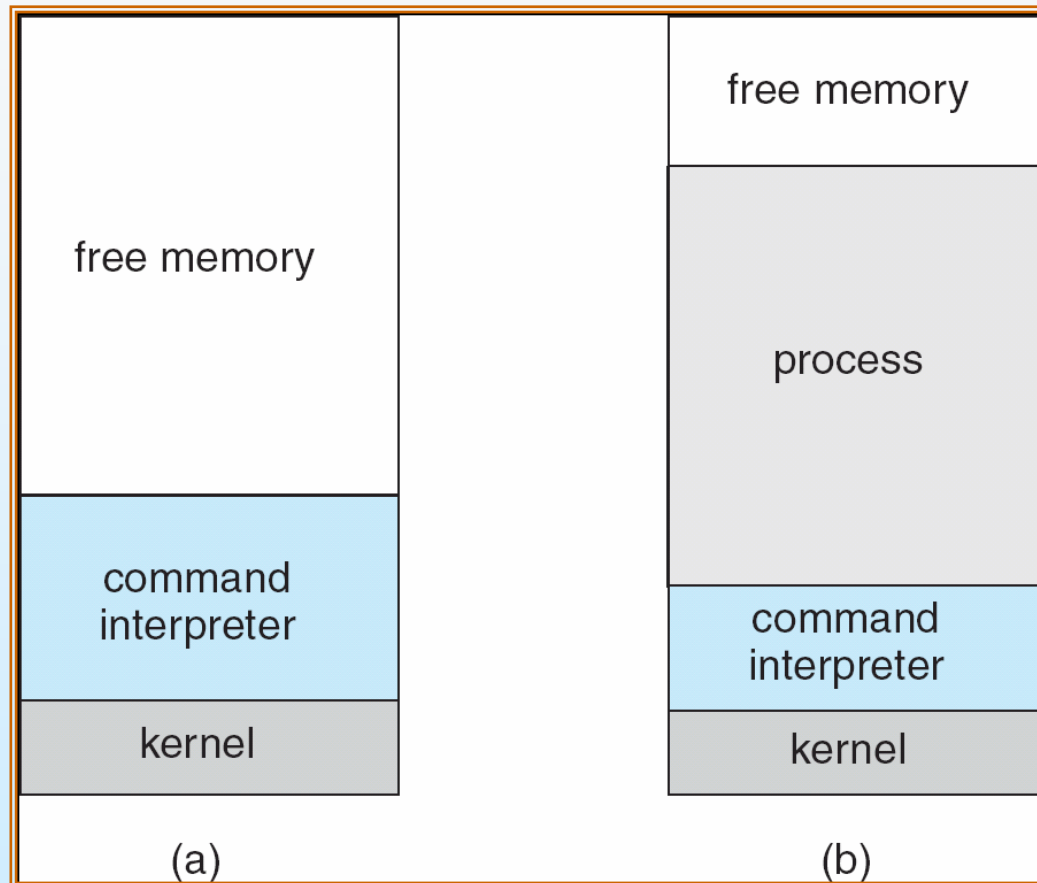

(a) At system startup (b) running a program





# FreeBSD Running Multiple Programs

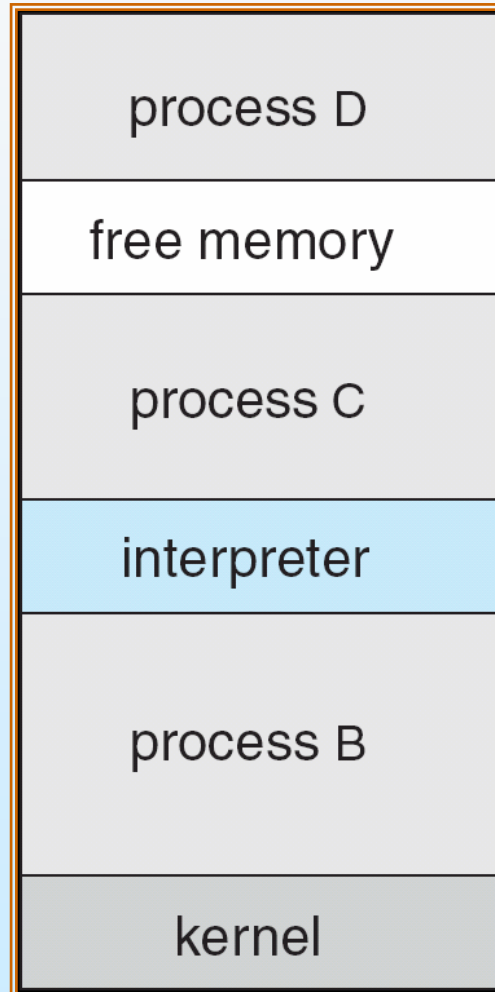



# System Programs

- System programs provide a convenient environment for program development and execution. They can be divided into:
  - File manipulation
  - Status information
  - File modification
  - Programming language support
  - Program loading and execution
  - Communications
  - Application programs
- Most users' view of the operation system is defined by system programs, not the actual system calls





# Solaris 10 dtrace Following System Call

```
# ./all.d 'pgrep xclock' XEventsQueued
dtrace: script './all.d' matched 52377 probes
CPU FUNCTION
 0 -> XEventsQueued          U
 0  -> _XEventsQueued        U
 0   -> _X11TransBytesReadable U
 0  <- _X11TransBytesReadable U
 0   -> _X11TransSocketBytesReadable U
 0  <- _X11TransSocketBytesreadable U
 0   -> ioctl                U
 0    -> ioctl                K
 0     -> getf                 K
 0      -> set_active_fd      K
 0       <- set_active_fd    K
 0        <- getf             K
 0         -> get_umatamodel  K
 0          <- get_umatamodel K
...
 0           -> releasef      K
 0            -> clear_active_fd K
 0             <- clear_active_fd K
 0              -> cv_broadcast K
 0               <- cv_broadcast K
 0                <- releasef  K
 0                 <- ioctl    K
 0                  <- ioctl    U
 0                   <- _XEventsQueued U
 0                    <- XEventsQueued U
```





# System Programs

- Provide a convenient environment for program development and execution
  - Some of them are simply user interfaces to system calls; others are considerably more complex
- File management - Create, delete, copy, rename, print, dump, list, and generally manipulate files and directories
- Status information
  - Some ask the system for info - date, time, amount of available memory, disk space, number of users
  - Others provide detailed performance, logging, and debugging information
  - Typically, these programs format and print the output to the terminal or other output devices
  - Some systems implement a registry - used to store and retrieve configuration information





# System Programs (cont'd)

- File modification
  - Text editors to create and modify files
  - Special commands to search contents of files or perform transformations of the text
- Programming-language support - Compilers, assemblers, debuggers and interpreters sometimes provided
- Program loading and execution- Absolute loaders, relocatable loaders, linkage editors, and overlay-loaders, debugging systems for higher-level and machine language
- Communications - Provide the mechanism for creating virtual connections among processes, users, and computer systems
  - Allow users to send messages to one another's screens, browse web pages, send electronic-mail messages, log in remotely, transfer files from one machine to another





# Operating System Design and Implementation

- Design and Implementation of OS not “solvable”, but some approaches have proven successful
- Internal structure of different Operating Systems can vary widely
- Start by defining goals and specifications
- Affected by choice of hardware, type of system
- *User* goals and *System* goals
  - User goals – operating system should be convenient to use, easy to learn, reliable, safe, and fast
  - System goals – operating system should be easy to design, implement, and maintain, as well as flexible, reliable, error-free, and efficient







# Operating System Design and Implementation (Cont.)

- Important principle to separate

**Policy:** What will be done?

**Mechanism:** How to do it?

- Mechanisms determine how to do something, policies decide what will be done
  - The separation of policy from mechanism is a very important principle, it allows maximum flexibility if policy decisions are to be changed later





# Simple Structure

- MS-DOS – written to provide the most functionality in the least space
  - Not divided into modules
  - Although MS-DOS has some structure, its interfaces and levels of functionality are not well separated





# MS-DOS Layer Structure

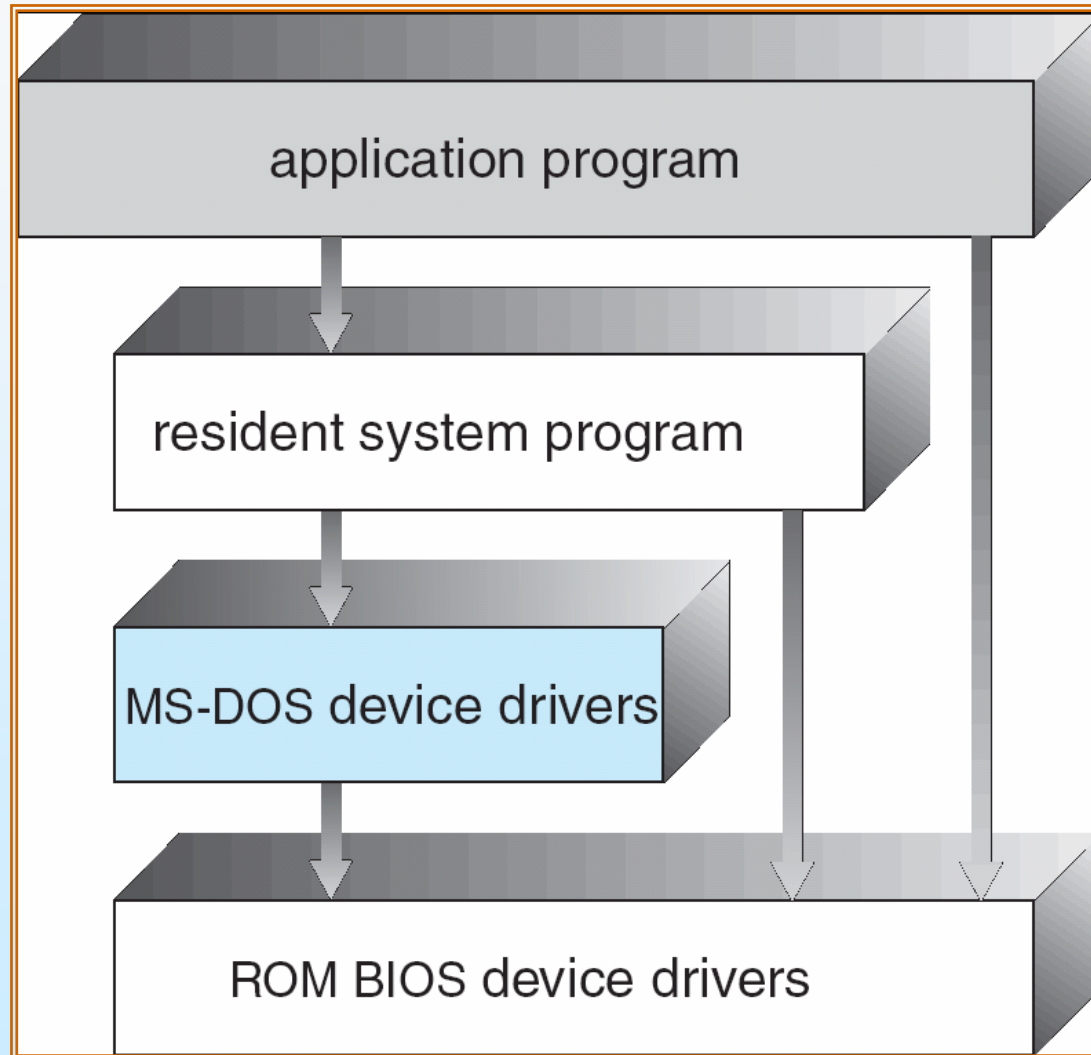



# Layered Approach

- The operating system is divided into a number of layers (levels), each built on top of lower layers. The bottom layer (layer 0), is the hardware; the highest (layer N) is the user interface.
- With modularity, layers are selected such that each uses functions (operations) and services of only lower-level layers





# Layered Operating System

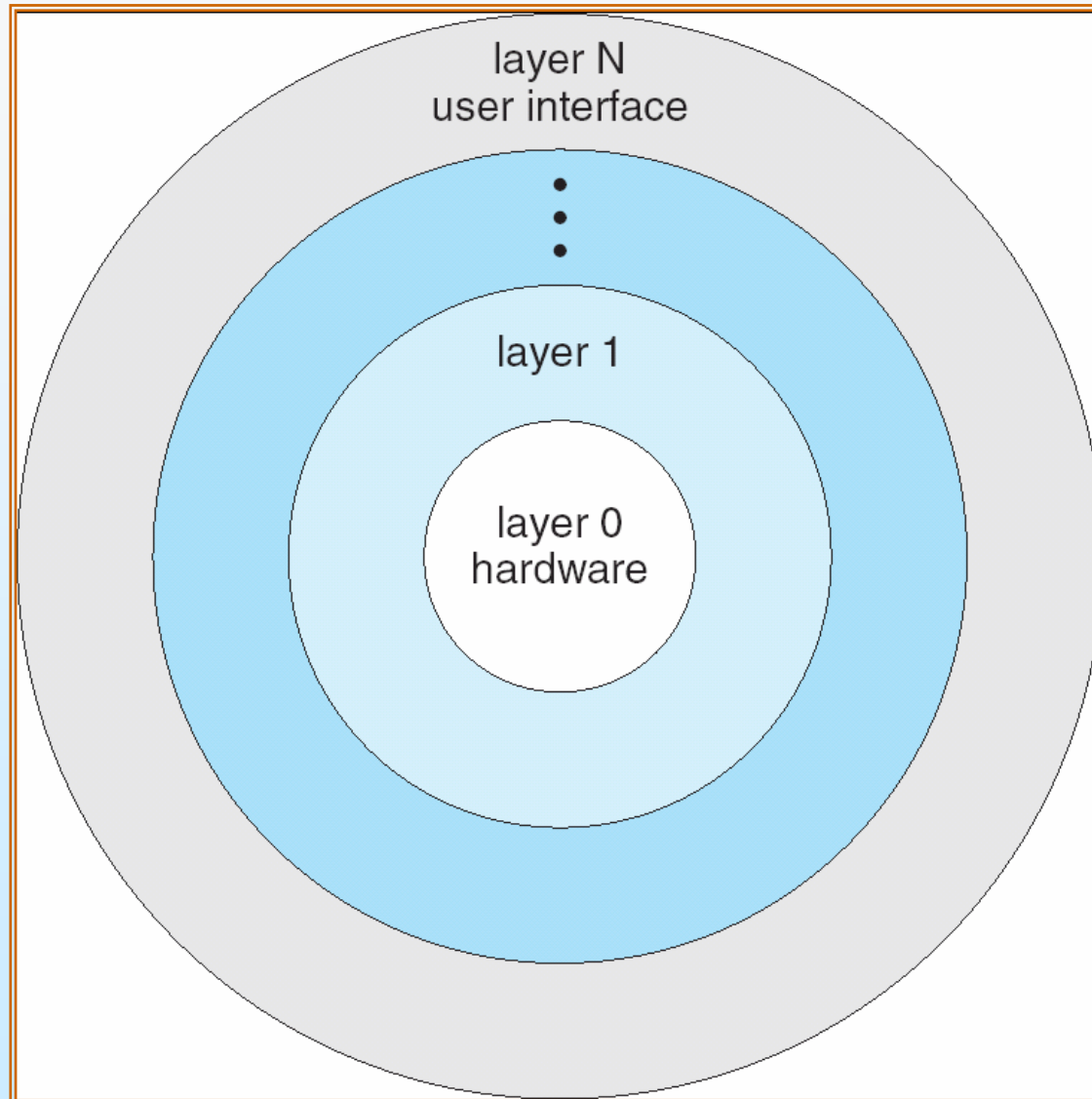



# UNIX

- UNIX – limited by hardware functionality, the original UNIX operating system had limited structuring. The UNIX OS consists of two separable parts
  - Systems programs
  - The kernel
    - ▶ Consists of everything below the system-call interface and above the physical hardware
    - ▶ Provides the file system, CPU scheduling, memory management, and other operating-system functions; a large number of functions for one level





# UNIX System Structure

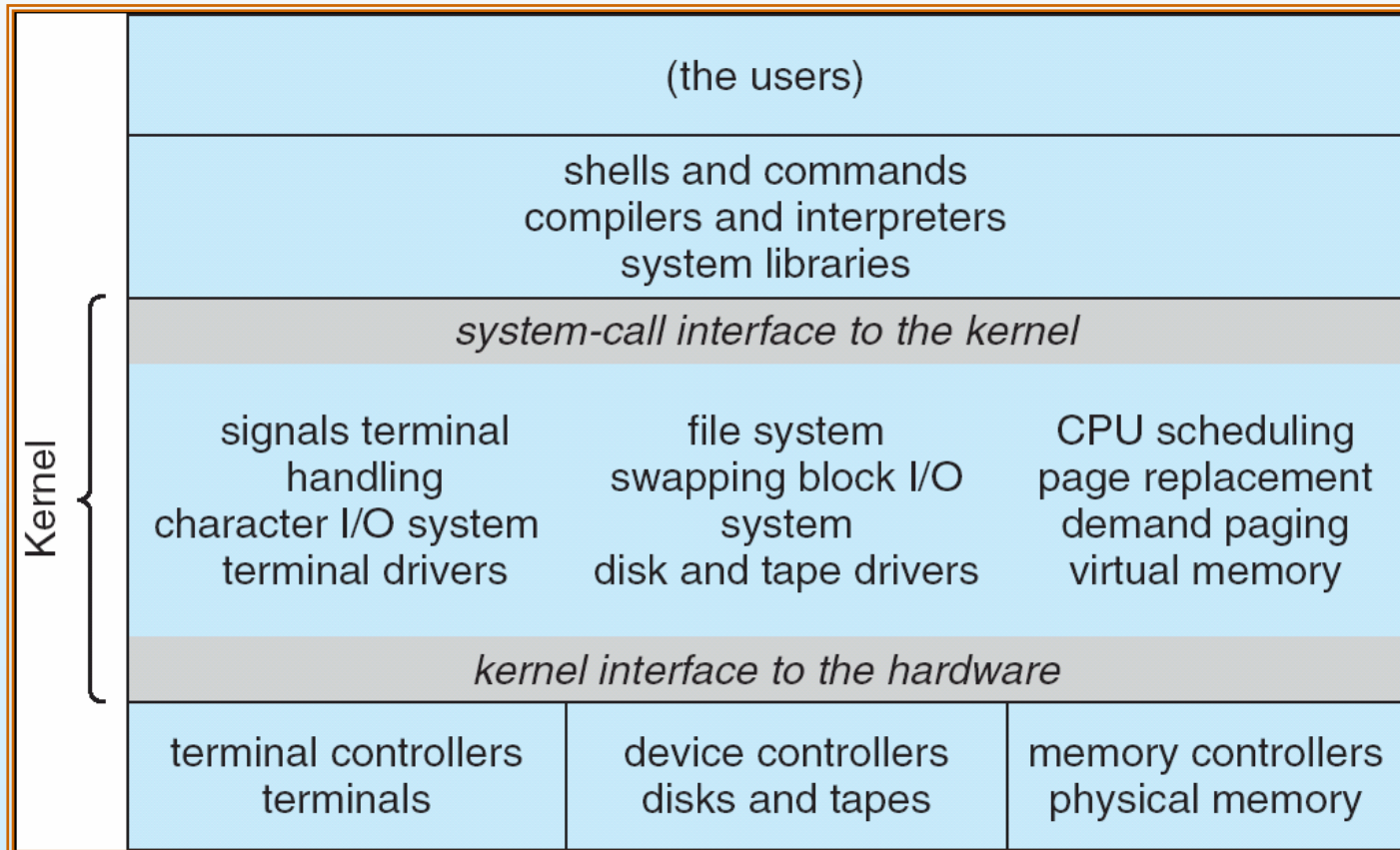



# Microkernel System Structure

- Moves as much from the kernel into “*user*” space
- Communication takes place between user modules using message passing
- Benefits:
  - Easier to extend a microkernel
  - Easier to port the operating system to new architectures
  - More reliable (less code is running in kernel mode)
  - More secure
- Detriments:
  - Performance overhead of user space to kernel space communication







# Mac OS X Structure

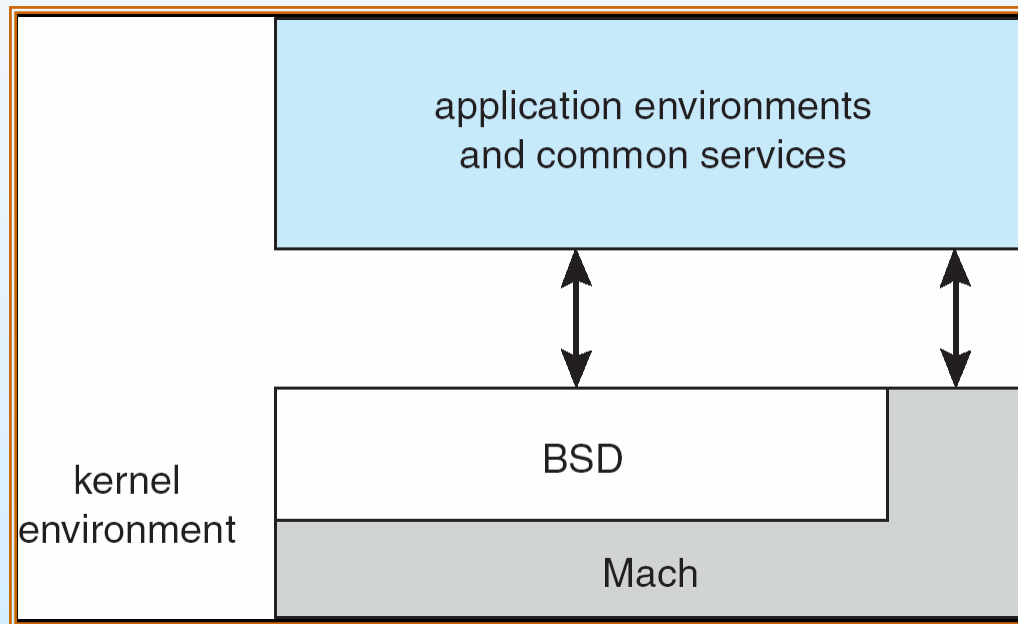



# Modules

- Most modern operating systems implement kernel modules
  - Uses object-oriented approach
  - Each core component is separate
  - Each talks to the others over known interfaces
  - Each is loadable as needed within the kernel
- Overall, similar to layers but with more flexible





# Solaris Modular Approach

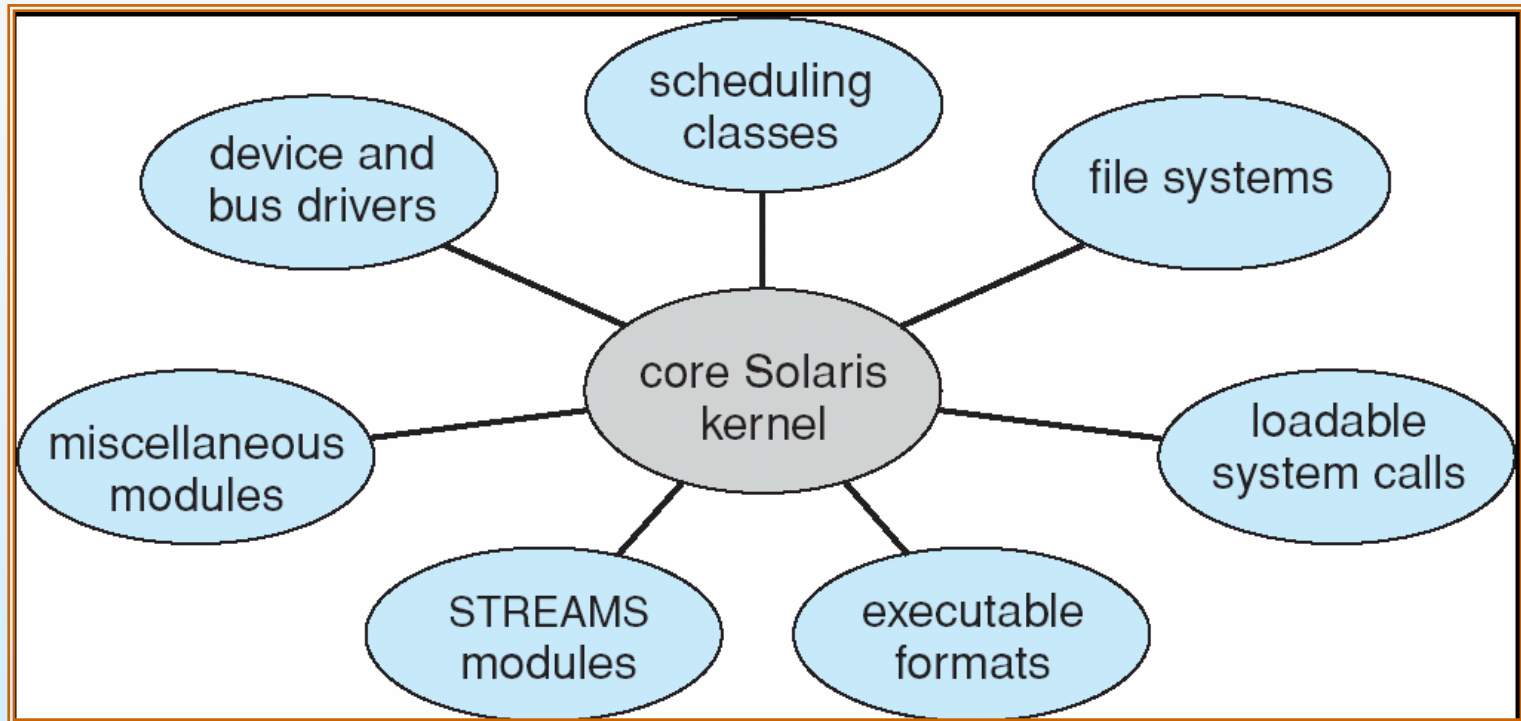



# Virtual Machines

- A *virtual machine* takes the layered approach to its logical conclusion. It treats hardware and the operating system kernel as though they were all hardware
- A virtual machine provides an interface *identical* to the underlying bare hardware
- The operating system creates the illusion of multiple processes, each executing on its own processor with its own (virtual) memory





# Virtual Machines (Cont.)

- The resources of the physical computer are shared to create the virtual machines
  - CPU scheduling can create the appearance that users have their own processor
  - Spooling and a file system can provide virtual card readers and virtual line printers
  - A normal user time-sharing terminal serves as the virtual machine operator's console





# Virtual Machines (Cont.)

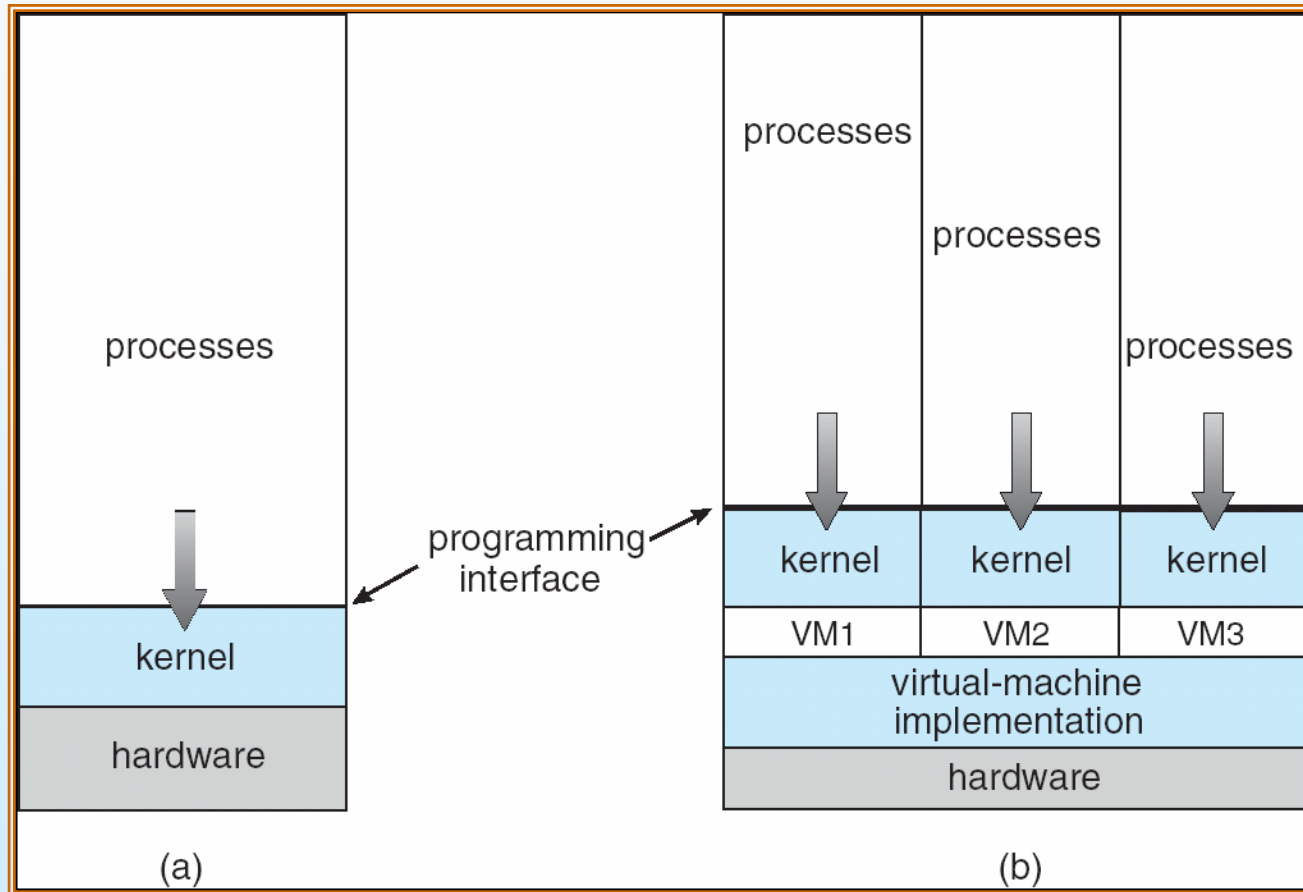

(a) Nonvirtual machine (b) virtual machine





# Virtual Machines (Cont.)

- The virtual-machine concept provides complete protection of system resources since each virtual machine is isolated from all other virtual machines. This isolation, however, permits no direct sharing of resources.
- A virtual-machine system is a perfect vehicle for operating-systems research and development. System development is done on the virtual machine, instead of on a physical machine and so does not disrupt normal system operation.
- The virtual machine concept is difficult to implement due to the effort required to provide an *exact* duplicate to the underlying machine





# VMware Architecture

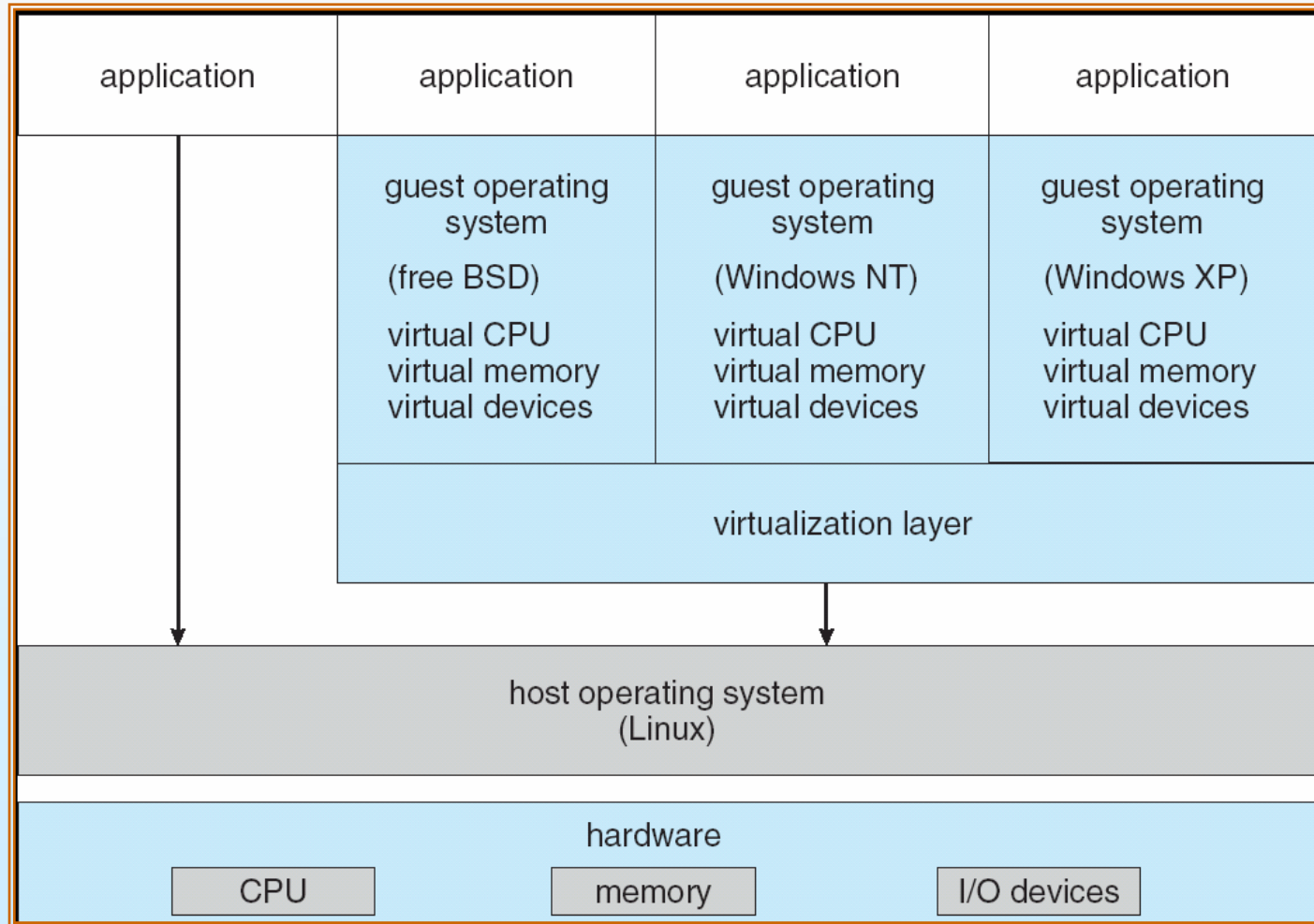





# The Java Virtual Machine

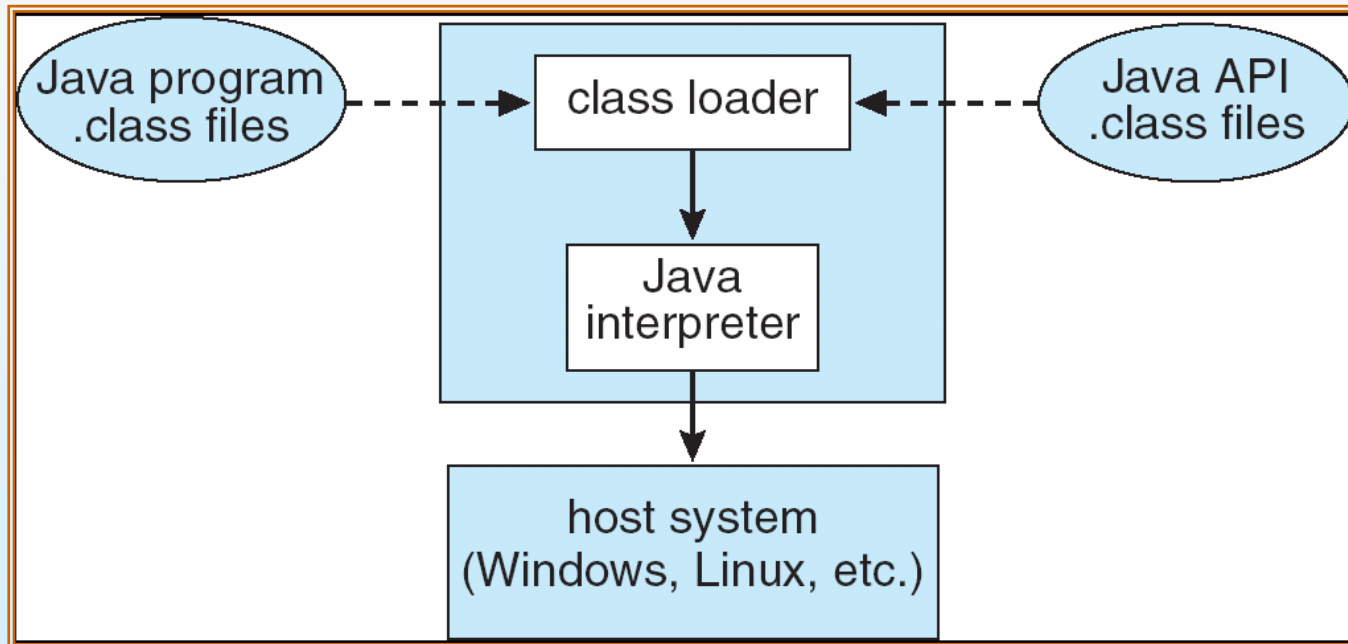



# Operating System Generation

- Operating systems are designed to run on any of a class of machines; the system must be configured for each specific computer site
- SYSGEN program obtains information concerning the specific configuration of the hardware system
- *Booting* – starting a computer by loading the kernel
- *Bootstrap program* – code stored in ROM that is able to locate the kernel, load it into memory, and start its execution





# System Boot

- Operating system must be made available to hardware so hardware can start it
  - Small piece of code – **bootstrap loader**, locates the kernel, loads it into memory, and starts it
  - Sometimes two-step process where **boot block** at fixed location loads bootstrap loader
  - When power initialized on system, execution starts at a fixed memory location
    - ▶ Firmware used to hold initial boot code



# End of Chapter 2

